

Estimator for SketchUp

Estimator for SketchUp © is a simple but powerful real-time estimating extension allowing SketchUp users to generate accurate take-offs and complete estimates for all costs associated with their project, without ever having to leave SketchUp.

The user interface consists of five tabs - the first four are used to add cost data and generate take-offs and the last tab is for reporting results.

Components Tab

A component may be a stud, a bolt, a dishwasher, a window, etc. Components may also be nested components, meaning they have components inside the component. You can assign a cost code for sorting results (from your own custom cost codes list or with the pre-loaded Cost Codes from the National Association of Home Builders), a Description (which allows for similar components to be grouped if desired), enter a Vendor or choose a Vendor from your custom vendor list, add a unit rate and choose the unit to be displayed from a custom list or simply typing in desired units, a labor amount associated with it if any, a waste factor and sales tax to any and all components in the model. This data may be saved with the component for use in future models. Let's take a look at this deck post component (figure 1).

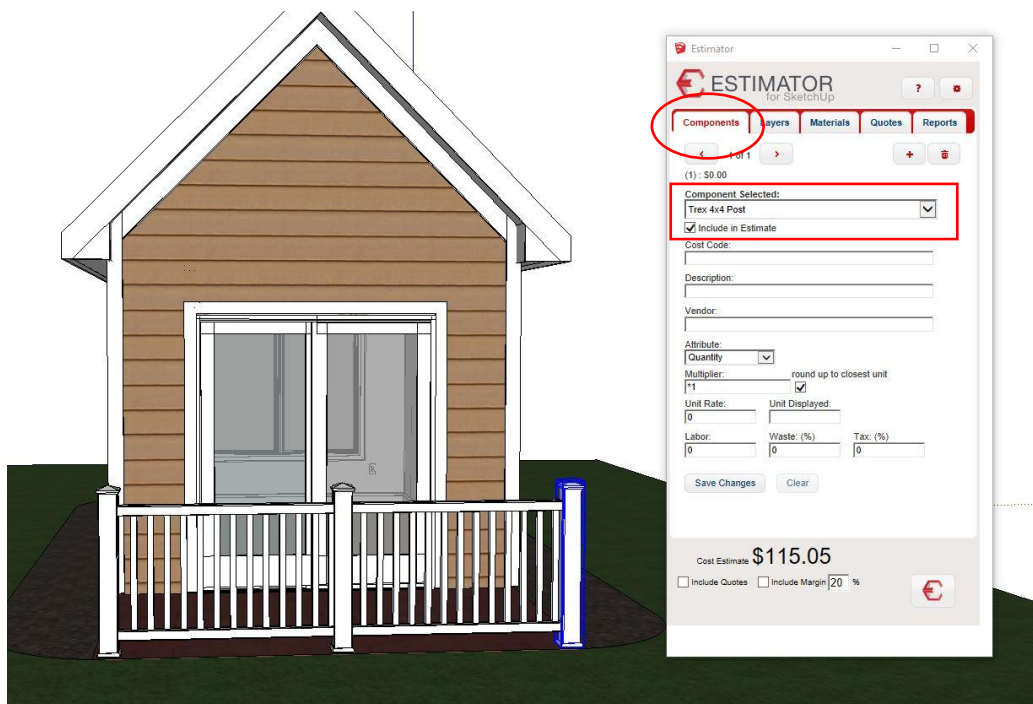

Figure 1

Select the Component Tab and the Component Selection box displays the name of the component. Notice the drop-down box, this post has three components nested. Each of these components have cost data stored as these items are purchased separately. There is a skirt (figure 2), a sleeve (figure 3) and a cap (figure 4).

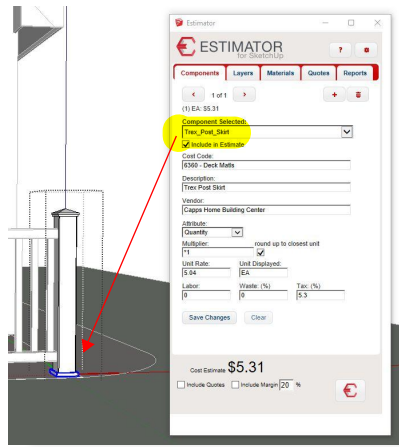

Figure 2

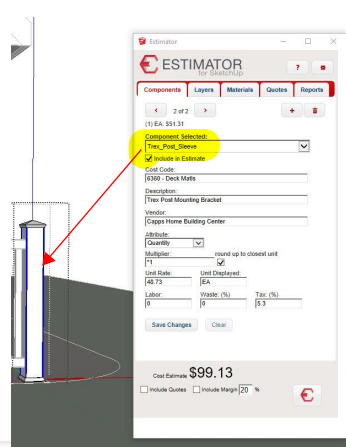

Figure 3

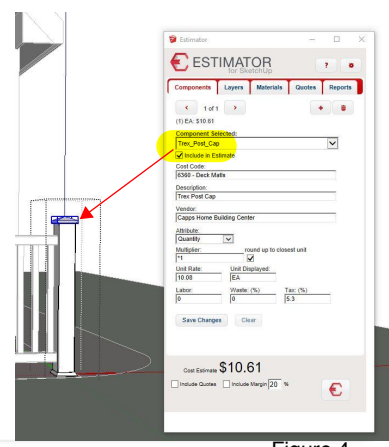

Figure 4

Sub-totals for selected components will show here (figure 5).

There are two other powerful features that allow you to expand your estimating capabilities using Components. The first feature is the ability to “Add Associated Costs” to each component by clicking the + button (figure 6). For example, this deck railing post sleeve fits over a 4x4 post or a steel bracket bolted to the deck. You may choose to ADD ASSOCIATED COST vs. modeling this bracket component. Click on the + button and fill out the data for the bracket that is associated with this sleeve. (figure 7) Similarly, these associated costs can be deleted by clicking on the trash icon (figure 8).

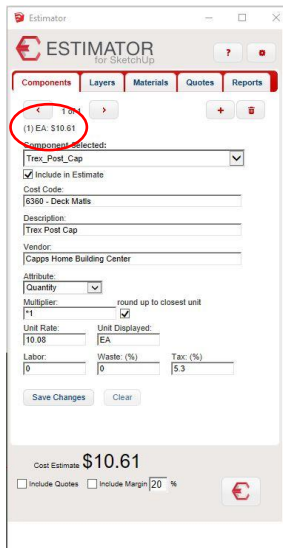

Figure 5

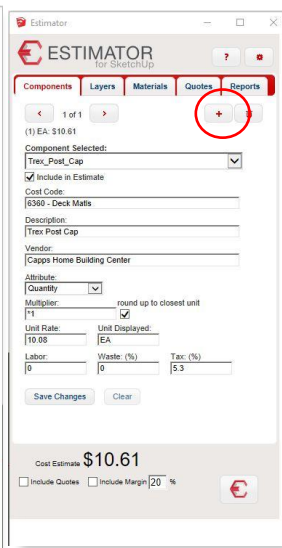

Figure 6

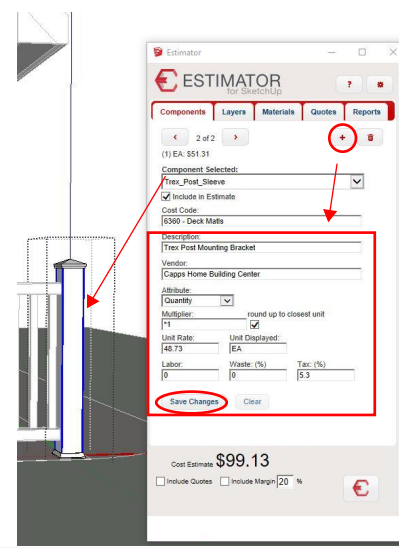

Figure 7

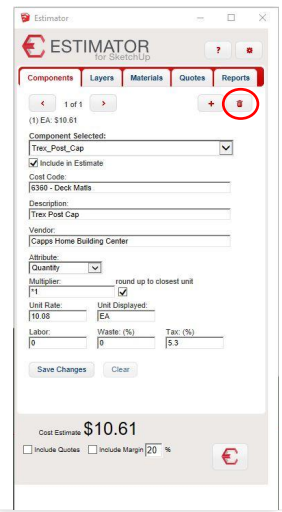

Figure 8

The second feature is the Description Box allowing you to group similar components of the same type, for example, this stud (figure 9), and the jack beside it (figure 10), which may cut out of a stud, name them both the same and they will report out grouped as the total of that item. (figure 11)

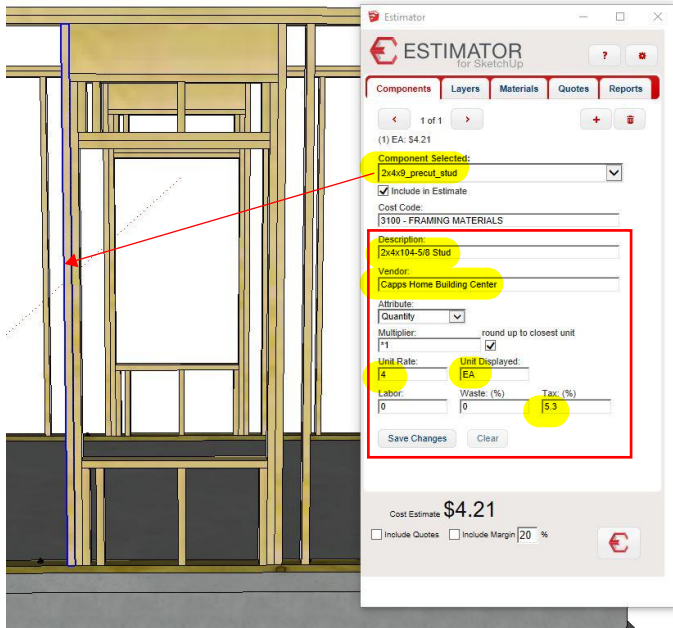

Figure 9

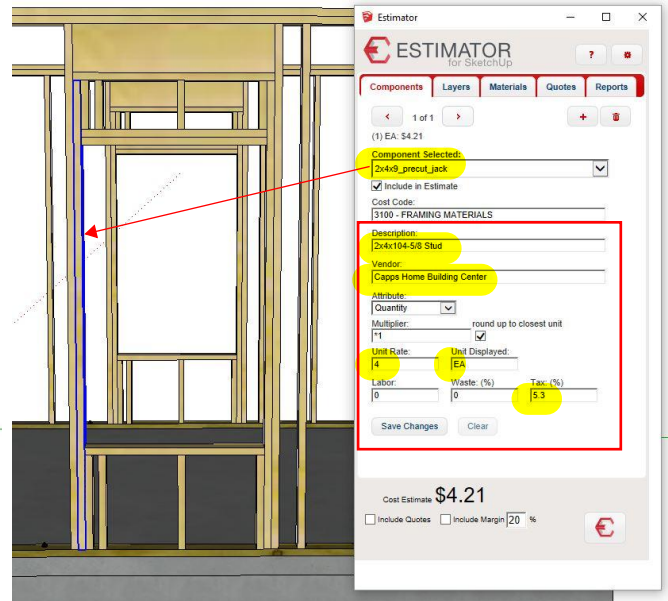

Figure 10

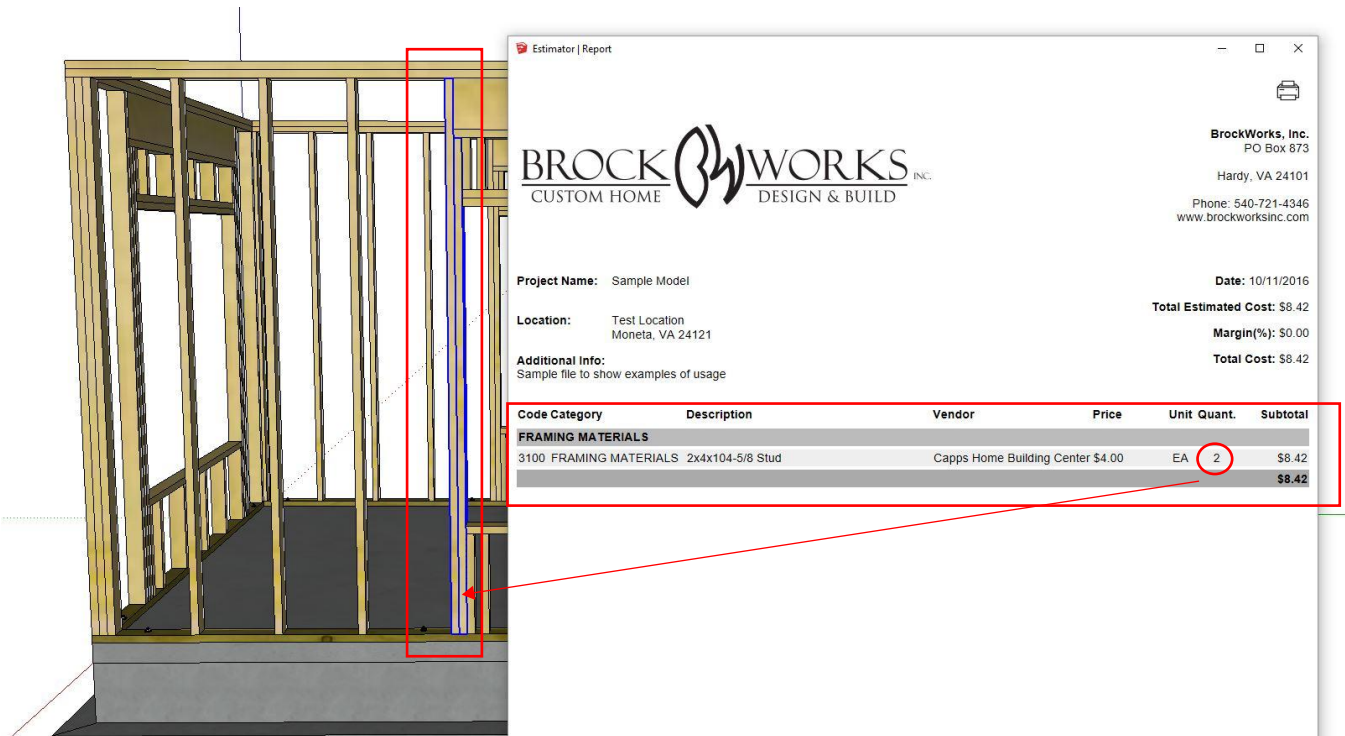

Figure 11

Layers Tab

Most geometry that is modeled have attributes of length, area, and volume. Estimators use these attributes to calculate materials and product quantities for each given item. For example, here is a concrete slab (figure 12) on a layer called "F00_Slab".

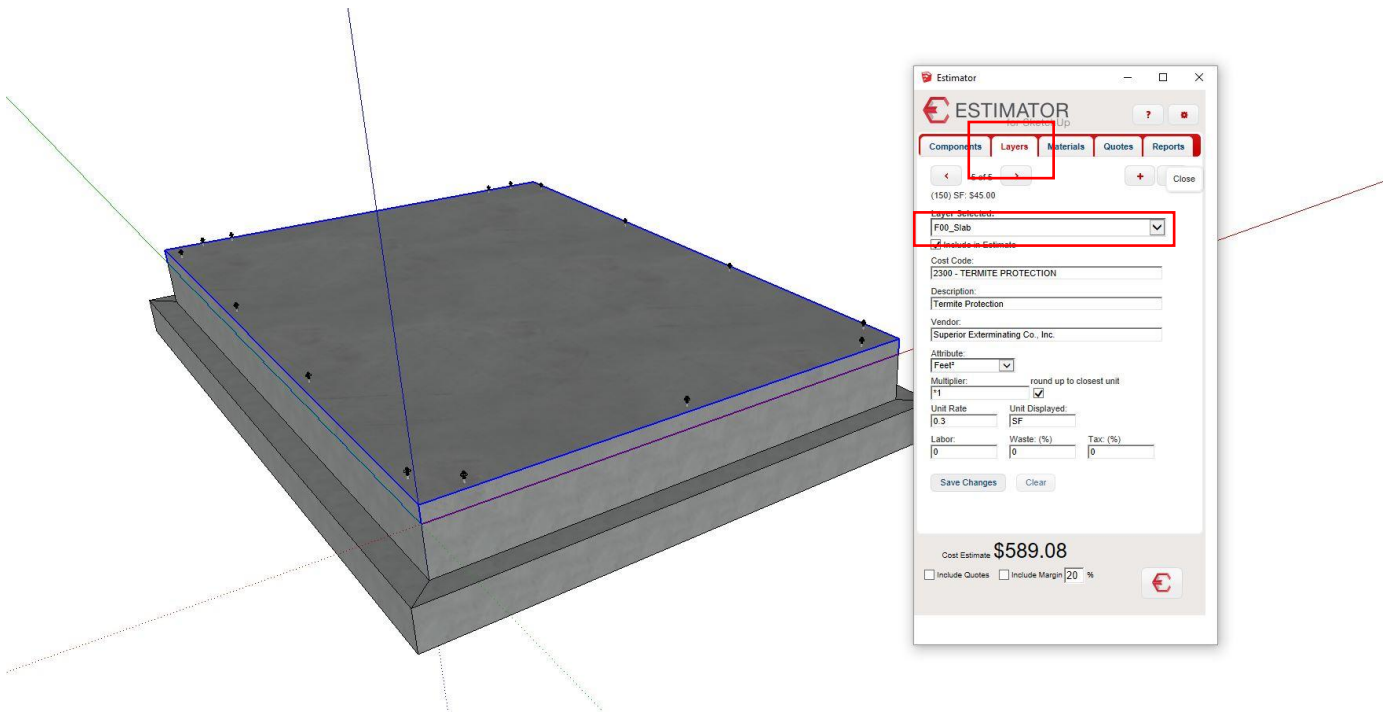

Figure 12

I may use the volume, or Cubic Yards in this case, and add a unit price for concrete, add waste and sales tax, Save Changes and view the sub-total (figure 13) .

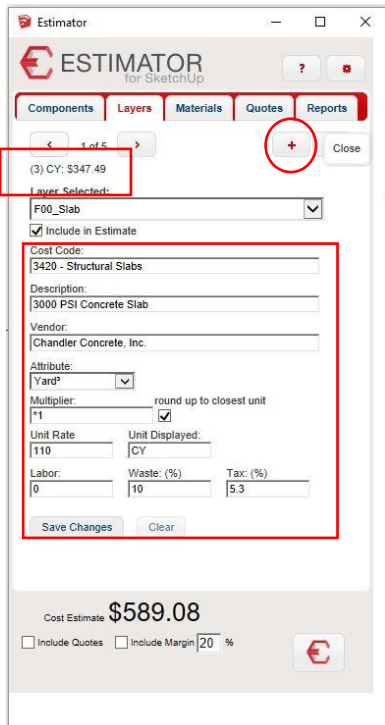

Figure 13

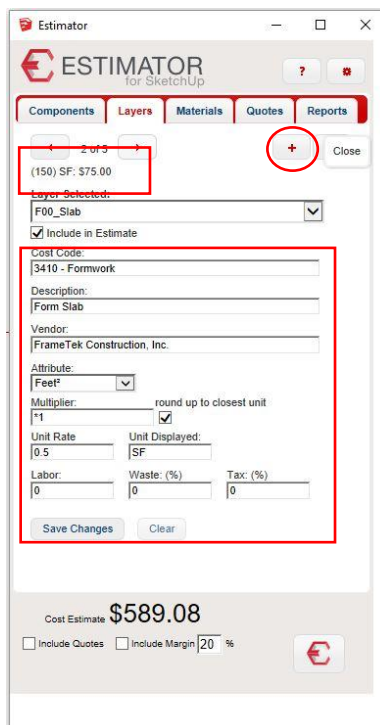

Figure 14

I may then ADD an "Associated Cost" and choose the area, or square footage, and add a unit cost for labor to form the slab (figure 14).

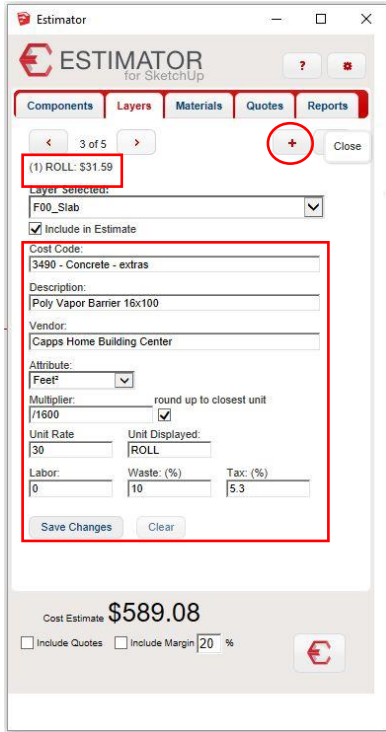

Figure 15

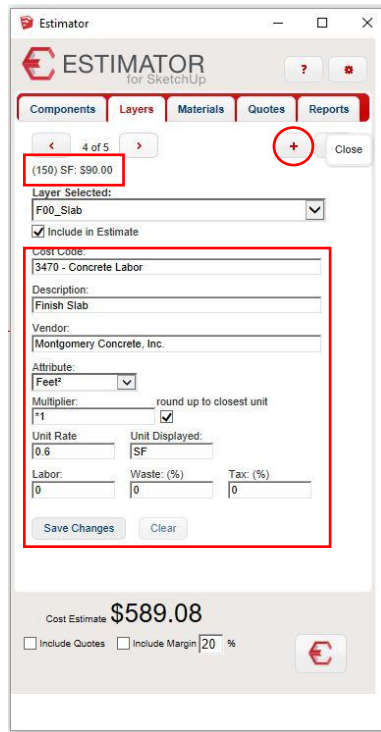

Figure 16

I may further add another associated cost, use the square footage and a “multiplier”, divide by 1600 (/1600) to calculate how many 16’ x 100’ rolls of poly vapor barrier I need under it - add waste factor, round up to nearest roll, add sales tax, etc. (figure 15)

I may further add another associated cost, use the square footage to assign a cost per square foot for the labor to finish the slab. (figure 16)

You may add as many associated costs as needed and the individual sub-totals of each item may be viewed for quick checks. Using layers is a great way to standardize your estimating system and avoid repetitive data entry by creating custom SketchUp templates that have cost data already stored to that layer the next time you create a basement slab, for example.

Another example of Layers are these 2x4’s (both treated and regular) and 2x10’s used for headers. (figure 17)

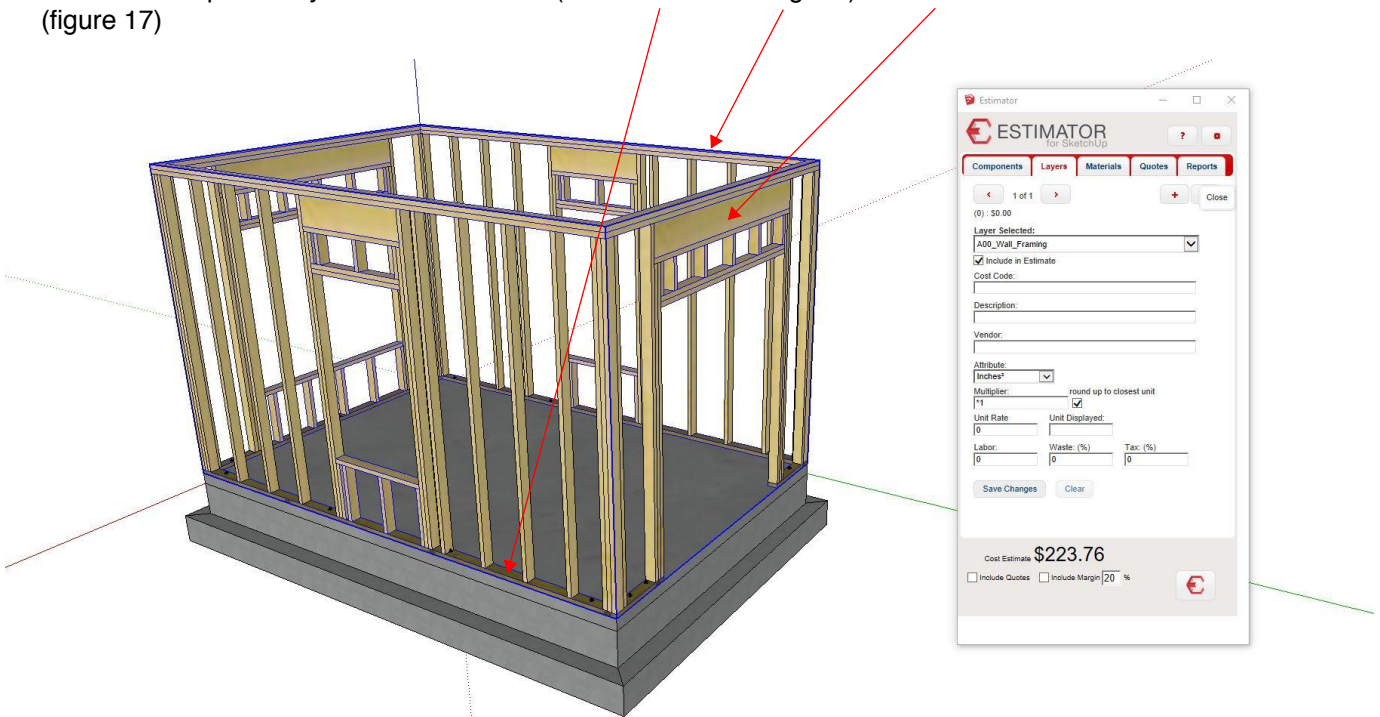

Figure 17

The Studs and Jacks are components, and the lineal footage of pressure-treated 2x4's, 2x4 SPF and 2x10 SYP were created using Profile Builder 2 (PB2), a highly recommended plugin created by Dale Martens, allowing you to choose ANY profile (be it lumber, baseboard, crown moulding, gutters, footings, etc.) and quickly model them, as well as create assemblies using multiple profiles and components.

Using the Layers Tab allows you to use the lineal footage of each profile and apply a simple multiplier to convert the lineal footage into the number of boards of a desired length for example, 2x4x16' SPF plates, we used a multiplier of /16, add waste and sales tax (see figure 18), and Estimator will report out the total pieces to order (figure 19). Again, once you have established material costs for these profiles, you will instantly be able to report their costs once they are modeled.

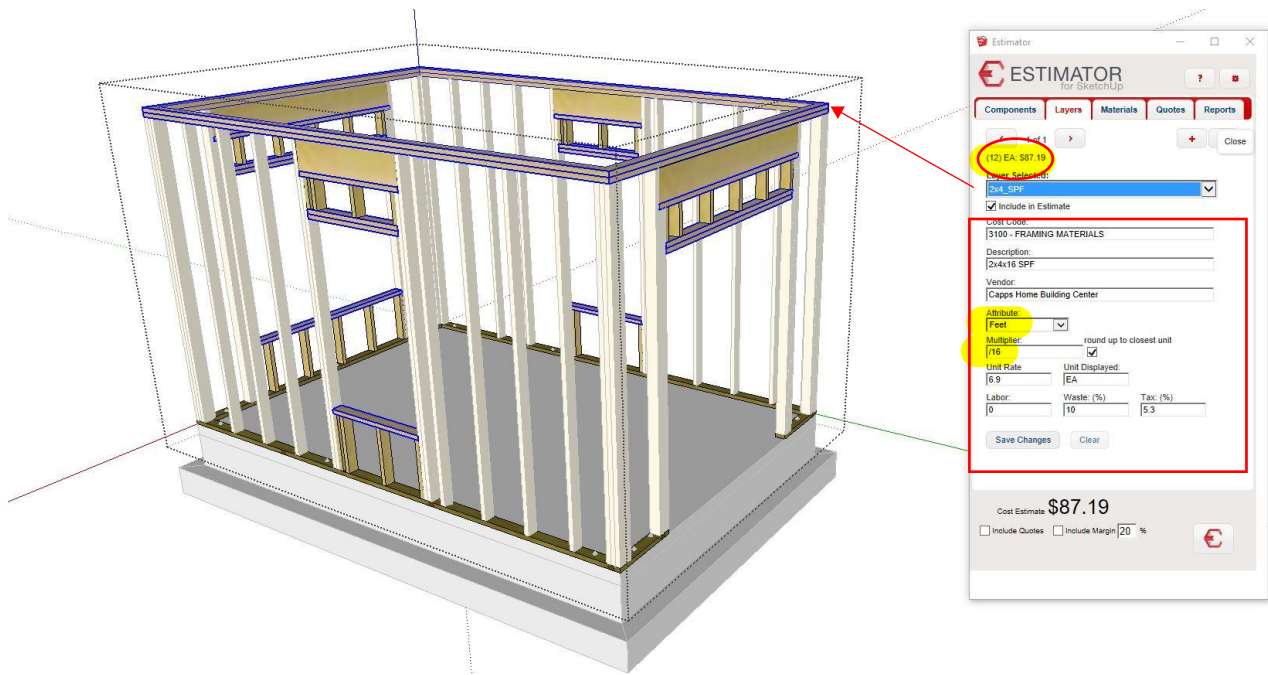

Figure 18

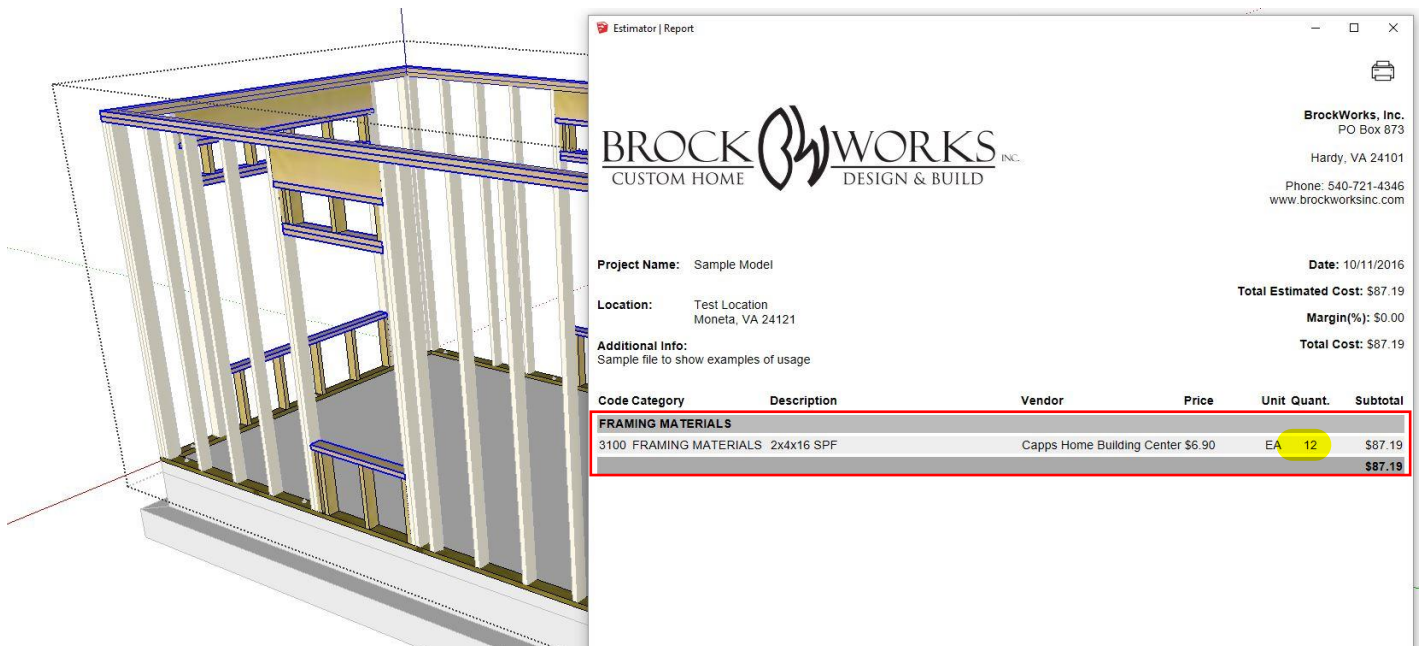

Figure 19

Materials Tab

Materials are basically an estimating tool used to account for all costs associated with an assigned material. For example, this roof (figure 20) - you can see shingles on the top portion of this roof and OSB sheathing on the bottom. You will notice a drop-down in the Material Selected box that will display all of the material files in the current SketchUp selection. You can choose a shingle texture, add an entry for shingle materials, and a multiplier of /100 to generate the number of squares (100sf) of shingles to order (figure 21).

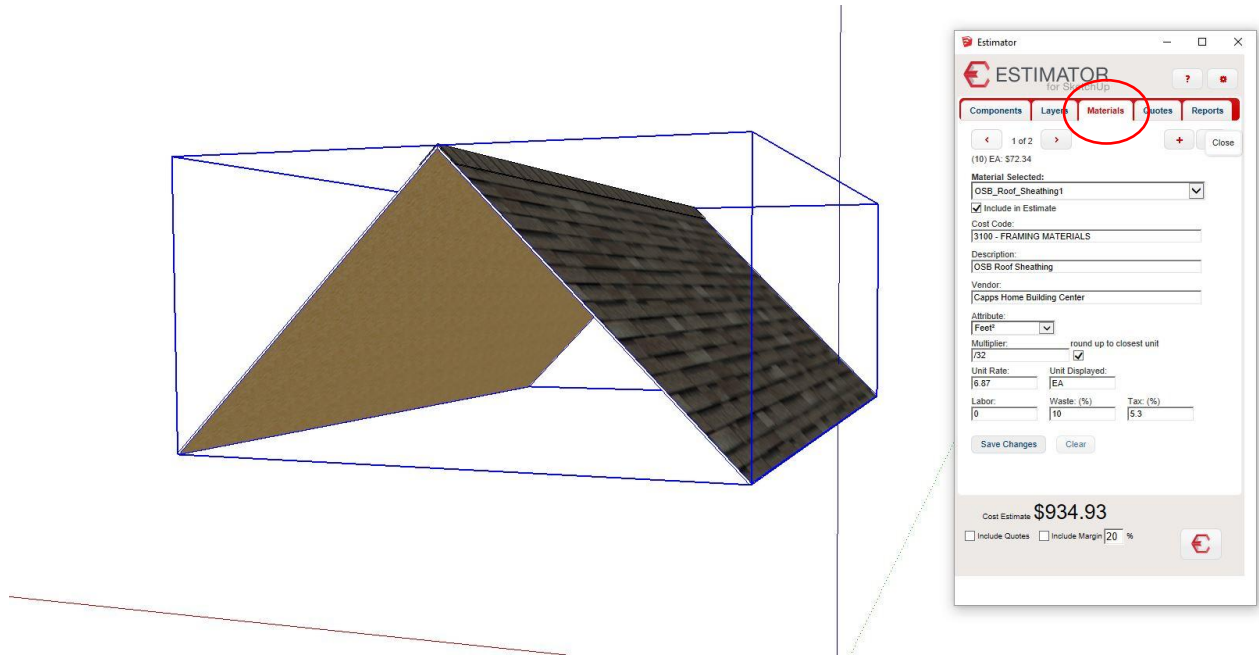

Figure 20

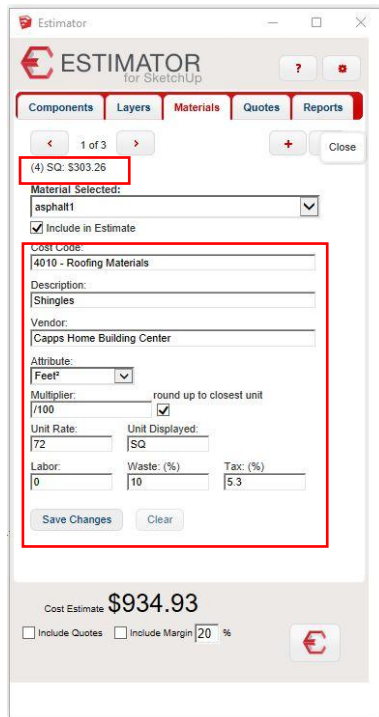

Figure 21

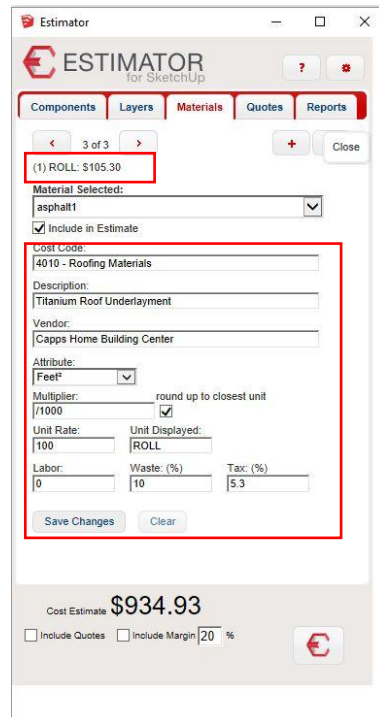

Figure 22

You may then add an associated cost for labor, another for calculating the rolls of roofing underlayment or boxes of nails, etc. (figure 22)

You may then choose the OSB roof sheathing material and a multiplier to convert into how many sheets will be required (figure 23), and boxes of nails (figure 24), etc.

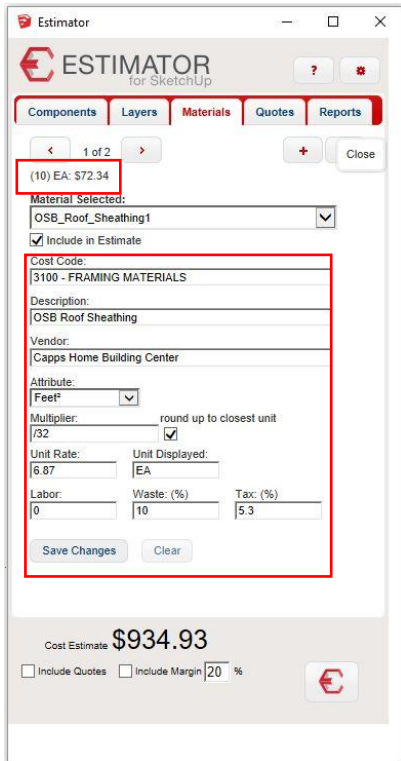

Figure 23

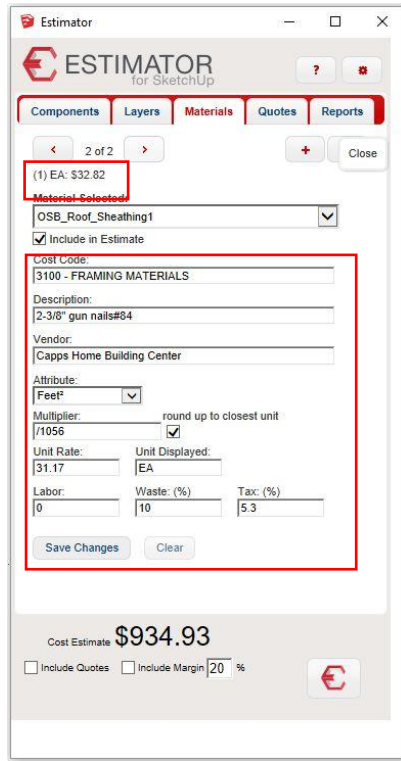

Figure 24

Notice too, in this roofing example, that there is a ridge cap on top (figure 25), once again the ridge caps were modeled using PB2 and costs assigned. To quickly report all of the costs associated with this roof, select both the roof and the ridge cap, then click on HTML Report in Reports (figure 26).

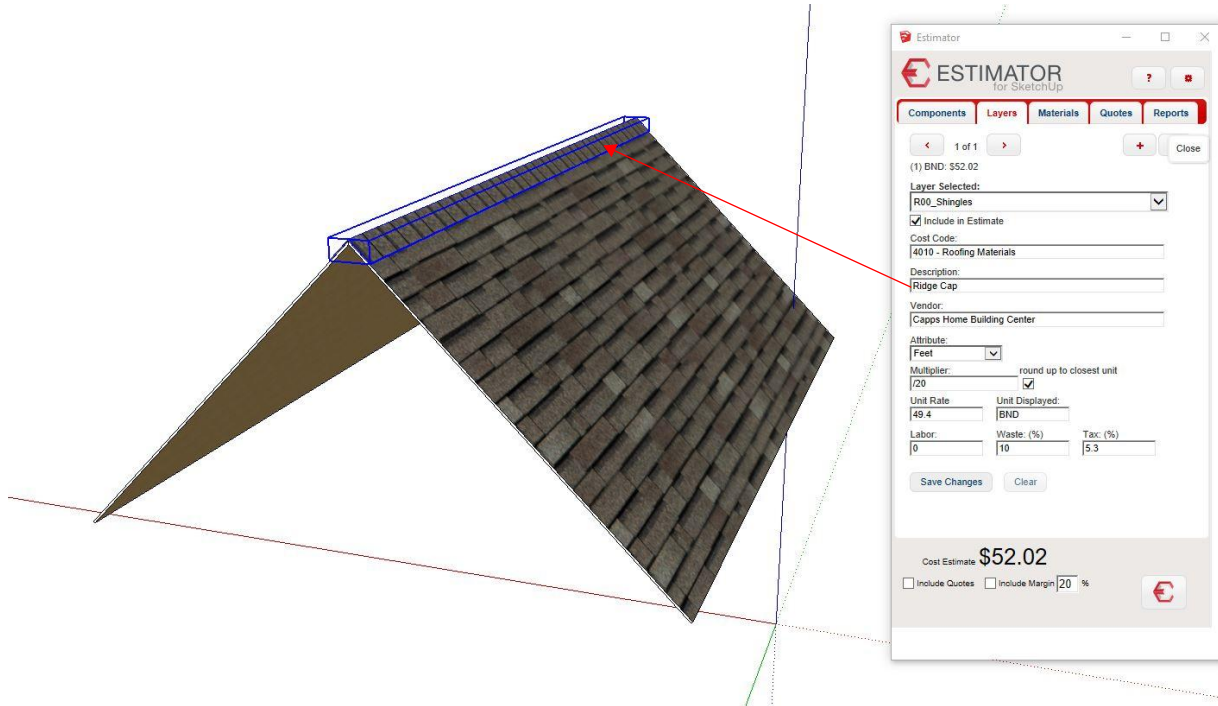

Figure 25

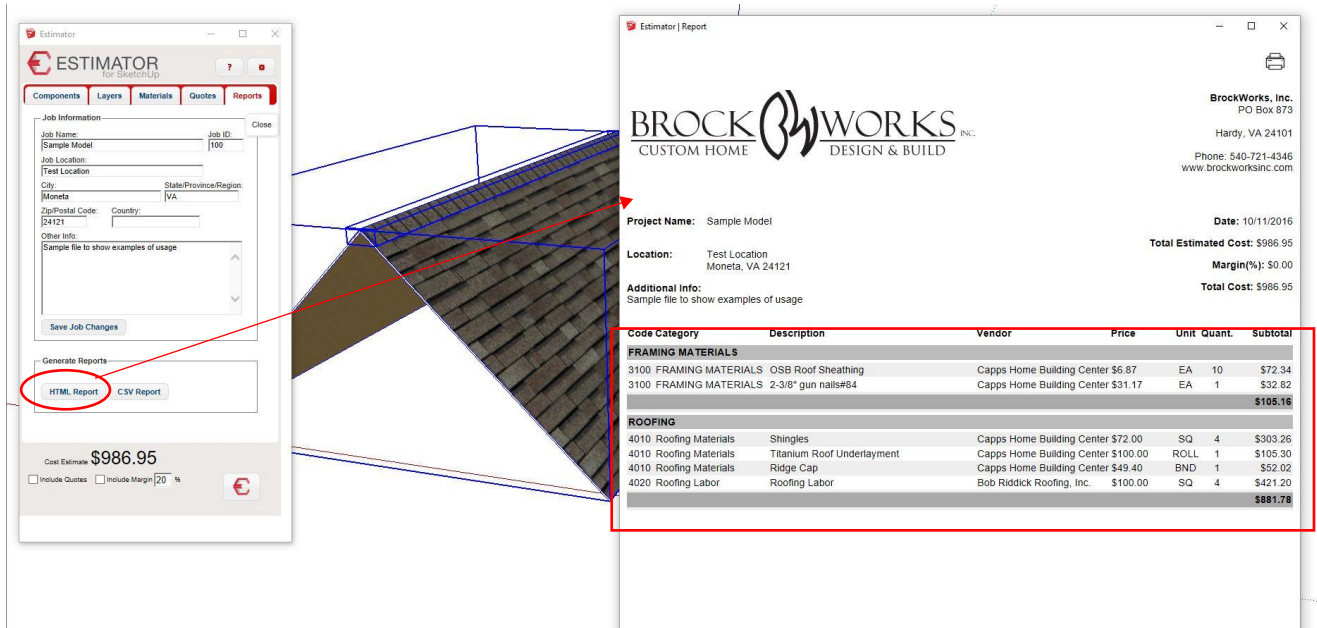

Figure 26

If you use cost per square foot methods to estimate, you can easily trace an area (for instance, finished square footage), paint it with a color or texture, and then assign a cost per square foot to estimate materials required or ballpark pricing.

Just as with Layers in a SketchUp template file, Materials and their associated cost data can be saved with that material for use in future models, thus saving a lot of time entering cost data.

Quotes Tab

Quotes allow you to add costs for intangible items such as framing labor or general conditions like portable toilet or dumpster - items not modeled or viewed but needed to complete the estimate 100% inside of SketchUp.

You may choose to enter a total amount (figure 27) or choose Unit Rate to enter Quantity and Unit Rate (figure 28).

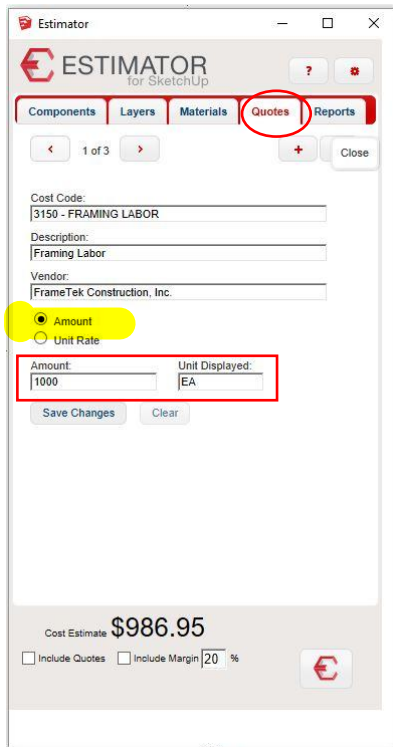

The screenshot shows the 'ESTIMATOR for SketchUp' interface with the 'Quotes' tab selected. The 'Amount' radio button is selected, and the 'Unit Rate' radio button is unselected. The 'Amount' field contains '1000' and the 'Unit Displayed' field contains 'EA'. The 'Cost Code' is '3150 - FRAMING LABOR' and the 'Description' is 'Framing Labor'. The 'Vendor' is 'FrameTek Construction, Inc.'. The total 'Cost Estimate' is '\$986.95'. There are checkboxes for 'Include Quotes' and 'Include Margin 20 %'.

Figure 27

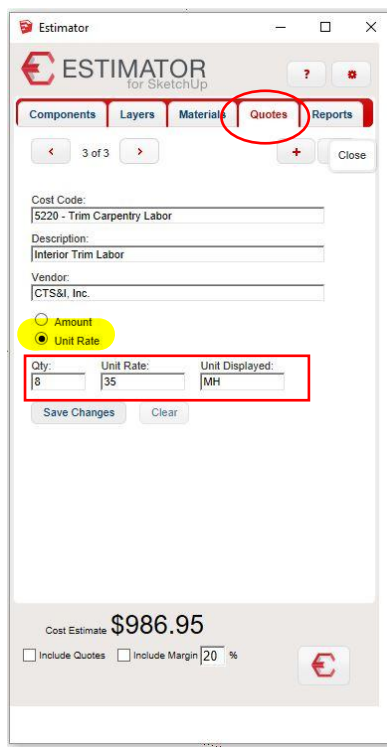

The screenshot shows the 'ESTIMATOR for SketchUp' interface with the 'Quotes' tab selected. The 'Unit Rate' radio button is selected, and the 'Amount' radio button is unselected. The 'City' field contains '8', the 'Unit Rate' field contains '35', and the 'Unit Displayed' field contains 'MH'. The 'Cost Code' is '5220 - Trim Carpentry Labor' and the 'Description' is 'Interior Trim Labor'. The 'Vendor' is 'CTS&I, Inc.'. The total 'Cost Estimate' is '\$986.95'. There are checkboxes for 'Include Quotes' and 'Include Margin 20 %'.

Figure 28

You may prefer to enter vendor or trade quotes versus individual components costs - in this case, any component can be excluded from showing up in the estimate when a quote is preferred.

For example, while designing this home, I used a cost associated with this individual window so that I can easily track costs as I design - I later received a quote from my vendor for the entire house full of windows - I may then uncheck the box next to "Include in Estimate" to simplify and avoid double cost entries (figure 29).

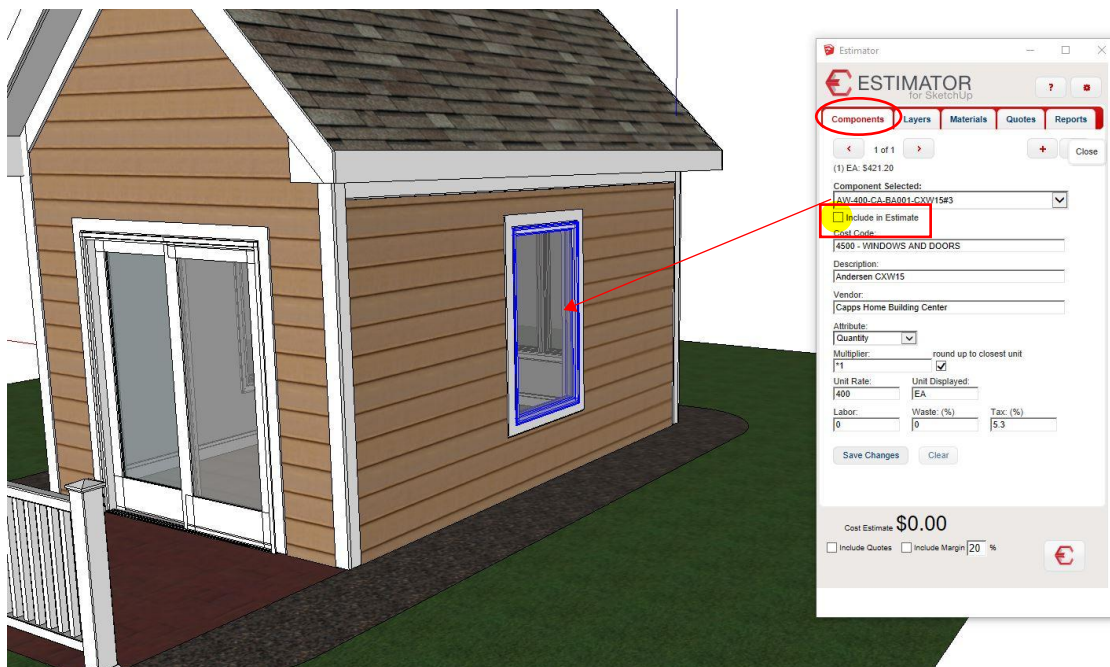

Figure 29

Reports Tab

Reports are where you may view real-time results for selected items in the model or the entire project. Job specific information is stored here for each project and will display on the report. (figure 30)

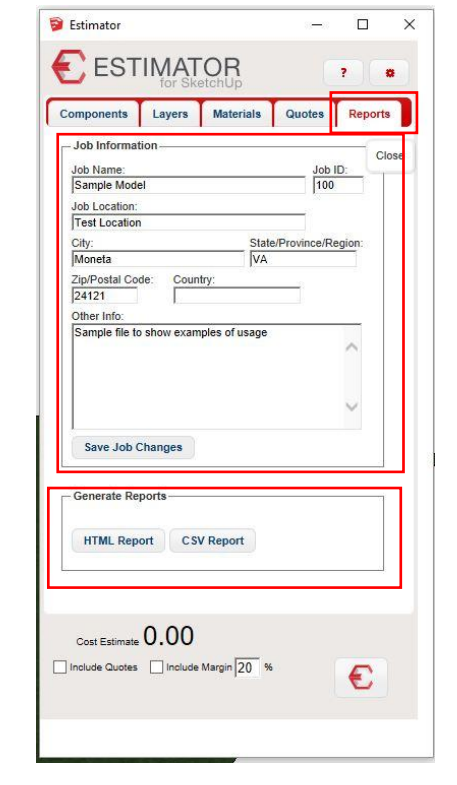

Figure 30

Automatic HTML reports may be generated instantly and easily printed at any time or reports may be exported to your favorite spreadsheet program for modifications, but not necessary as Estimator can possibly contain all the costs associated with a given project without ever having to leave SketchUp.

Again, it is all real-time, if you add an item, it is automatically in the estimate, remove it and it is deleted from the estimate - this really helps to avoid the process of making a change and then remembering to perform the same change in an estimating spreadsheet.

User Settings (figure 31)

Large models may contain a tremendous amount of data and Estimator is real-time and constantly monitoring for changes.

You may wish to turn off realtime reporting by un-checking the box next to "Realtime Reporting" (figure 32) to avoid any sluggishness while modeling OR simply close the Estimator UI while working.



Figure 31



Figure 32

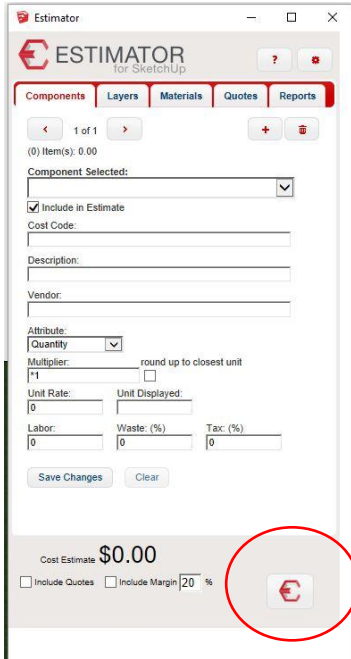

Figure 33

When Realtime Reporting is turned off, you may still generate an estimate for any given selection by simply clicking on the Estimator Icon (figure 33) at the bottom to generate the results.

You may customize Estimator by using your own Cost Codes, Vendors list (exported from accounting system, etc.) and desired Units Displayed.

These are all CSV files that you may edit to customize for your operation (figure 34).

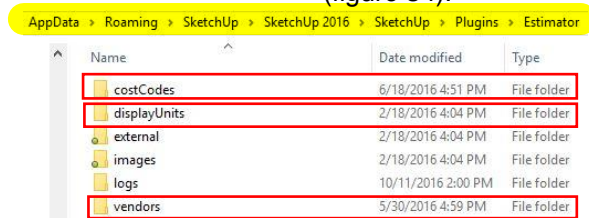

Figure 34

Company information stores your company data, which will show up on your reports (figure 35). This information is stored with the computer being used so it does not have to be re-entered in each model.

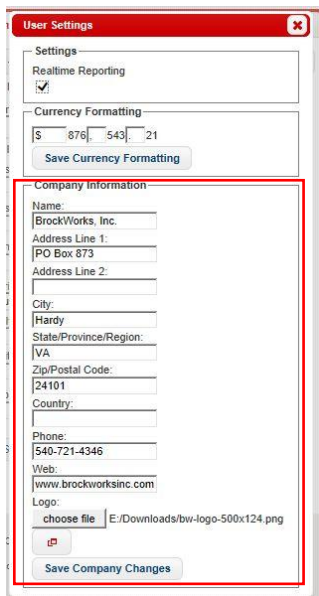

Figure 35

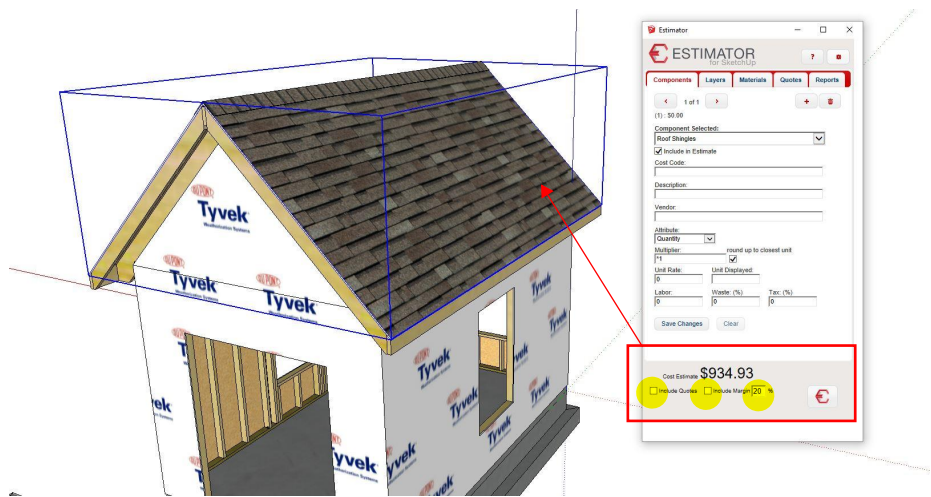

Figure 36

The bottom display in the User Interface is where the real-time Cost Estimate may be viewed and will display all costs associated with anything selected in the SketchUp model (figure 36). There is a checkbox to "Include Quotes" and a checkbox to "Include Margin" on the project (% of total cost estimate).

When you are ready to report costs for the entire project, simply select the entire model, check the box for include quotes and include margin and the total cost estimate is ready for review, printing and or exporting (figure 37).

ESTIMATOR for SketchUp

Job Information:
 Job Name: Sample Model Job ID: 100
 Job Location: Test Location
 Test Location: Moneta, VA 24121
 City: Moneta State/Province/Region: VA
 Zip/Postal Code: 24121 Country: USA
 Other info: Sample file to show examples of usage

Cost Estimate: **\$18,661.32**
 Include Quotes Include Margin

BROCKWORKS, INC.
 CUSTOM HOME DESIGN & BUILD

Project Name: Sample Model
 Location: Test Location, Moneta, VA 24121
 Date: 10/11/2016
 Total Estimated Cost: \$15,350.26
 Margin(20%): \$3,837.56
 Total Cost: \$19,187.82

Code Category	Description	Vendor	Price	Unit	Quant	Subtotal
PERMITS AND FEES						
1010 Building Permits	Building Permit	Franklin County Treasurer	\$100.00	EA	1	\$100.00
EXCAVATION AND BACKFILL						
2130 Gravel	Sub-Slab Gravel	Rockydate Quarries	\$20.00	TON	2	\$42.12
2170 Labor Footings/Foundation	Stem Wall Labor	Duane Davis Foundations, Inc.	\$10.00	LF	50	\$500.00
2170 Labor Footings/Foundation	Footing Labor	Duane Davis Foundations, Inc.	\$10.00	LF	51	\$510.00
2199 Footings/Foundation-Extras	Stem Wall concrete	Chandler Concrete, Inc.	\$110.00	CY	2	\$231.66
2199 Footings/Foundation-Extras	3000 PSI Concrete Footing	Chandler Concrete, Inc.	\$110.00	CY	3	\$347.49
2199 Footings/Foundation-Extras	1/2" Anchor Bolt	Capps Home Building Center	\$2.00	EA	15	\$31.59
WATERPROOFING						
2300 TERMITE PROTECTION	Termite Protection	Superior Exterminating Co., Inc.	\$0.30	SF	150	\$45.00
FRAMING MATERIALS						
3100 FRAMING MATERIALS	7/16 OSB wall sheathing	Capps Home Building Center	\$6.87	EA	14	\$101.28
3100 FRAMING MATERIALS	2-3/8" gun nails#84	Capps Home Building Center	\$31.17	EA	2	\$65.64
3100 FRAMING MATERIALS	Tyvek Housewrap 9x100	Capps Home Building Center	\$117.00	EA	1	\$123.20
3100 FRAMING MATERIALS	Tyvek Tape	Capps Home Building Center	\$8.00	ROLL	1	\$8.42
3100 FRAMING MATERIALS	OSB Roof Sheathing	Capps Home Building Center	\$6.87	EA	10	\$72.34

Figure 37

That concludes this quick overview of Estimator for SketchUp. Join the team and help us to continue to improve this powerful estimating system for SketchUp users - we have interactive forums for tips, suggested features, learn from others, etc., and tutorials to guide you along the way.

Please visit www.EstimatorForSketchUp.com for more information.